

PCTWORLD INTELLECTUAL PROPERTY ORGANIZATION
International Bureau

INTERNATIONAL APPLICATION PUBLISHED UNDER THE PATENT COOPERATION TREATY (PCT)

(51) International Patent Classification⁶ : C08F 10/06, 210/06, 4/64, 2/00	A1	(11) International Publication Number: WO 99/29742 (43) International Publication Date: 17 June 1999 (17.06.99)
(21) International Application Number: PCT/US98/24077 (22) International Filing Date: 12 November 1998 (12.11.98) (30) Priority Data: 60/069,189 10 December 1997 (10.12.97) US (71) Applicant: EXXON CHEMICAL PATENTS INC. [US/US]; 5200 Bayway Drive, Baytown, TX 77520-5200 (US). (72) Inventors: WENG, Weiquing; 13707 Shadow Falls Court, Houston, TX 77059 (US). DEKMEZIAN, Armenag, H.; 2806 Evergreen Cliff Trail, Kingwood, TX 77345 (US). MARKEL, Eric, J.; 4534 Natural Bridge Drive, Kingwood, TX 77345 (US). PETERS, David, L.; 14826 Hollydale, Houston, TX 77062 (US). (74) Agents: PEEBLES, Brent, M. et al.; Exxon Chemical Com- pany, P.O. Box 2149, Baytown, TX 77522-2149 (US).	(81) Designated States: BR, CA, CN, JP, KR, MX, SG, European patent (AT, BE, CH, CY, DE, DK, ES, FI, FR, GB, GR, IE, IT, LU, MC, NL, PT, SE). Published <i>With international search report. Before the expiration of the time limit for amending the claims and to be republished in the event of the receipt of amendments.</i>	
(54) Title: PROPYLENE POLYMERS INCORPORATING MACROMERS		
(57) Abstract <p>A polyolefin composition is provided which consists essentially of isotactic polypropylene and, optionally, one or more comonomers, wherein the total comonomer content of the polyolefin composition is from 0 to 20 mole percent, and further, wherein the weight average branching index g' for the lower molecular weight region of the polyolefin composition is less than 0.93. Additionally, a process is provided for producing a polyolefin composition comprising: a) contacting in solution, at a temperature from about 90 °C to about 120 °C, propylene monomers with a catalyst composition comprising a first chiral, stereorigid transition metal catalyst compound capable of producing isotactic polypropylene; b) copolymerizing the product of a) with propylene and, optionally, one or more copolymerizable monomers, in a polymerization reactor under suitable polypropylene polymerization conditions using a second chiral, stereorigid transition metal catalyst capable of producing isotactic polypropylene; and c) recovering a branched olefin polymer.</p>		

FOR THE PURPOSES OF INFORMATION ONLY

Codes used to identify States party to the PCT on the front pages of pamphlets publishing international applications under the PCT.

AL	Albania	ES	Spain	LS	Lesotho	SI	Slovenia
AM	Armenia	FI	Finland	LT	Lithuania	SK	Slovakia
AT	Austria	FR	France	LU	Luxembourg	SN	Senegal
AU	Australia	GA	Gabon	LV	Latvia	SZ	Swaziland
AZ	Azerbaijan	GB	United Kingdom	MC	Monaco	TD	Chad
BA	Bosnia and Herzegovina	GE	Georgia	MD	Republic of Moldova	TG	Togo
BB	Barbados	GH	Ghana	MG	Madagascar	TJ	Tajikistan
BE	Belgium	GN	Guinea	MK	The former Yugoslav Republic of Macedonia	TM	Turkmenistan
BF	Burkina Faso	GR	Greece	ML	Mali	TR	Turkey
BG	Bulgaria	HU	Hungary	MN	Mongolia	TT	Trinidad and Tobago
BJ	Benin	IE	Ireland	MR	Mauritania	UA	Ukraine
BR	Brazil	IL	Israel	MW	Malawi	UG	Uganda
BY	Belarus	IS	Iceland	MX	Mexico	US	United States of America
CA	Canada	IT	Italy	NE	Niger	UZ	Uzbekistan
CF	Central African Republic	JP	Japan	NL	Netherlands	VN	Viet Nam
CG	Congo	KE	Kenya	NO	Norway	YU	Yugoslavia
CH	Switzerland	KG	Kyrgyzstan	NZ	New Zealand	ZW	Zimbabwe
CI	Côte d'Ivoire	KP	Democratic People's Republic of Korea	PL	Poland		
CM	Cameroon	KR	Republic of Korea	PT	Portugal		
CN	China	KZ	Kazakstan	RO	Romania		
CU	Cuba	LC	Saint Lucia	RU	Russian Federation		
CZ	Czech Republic	LJ	Liechtenstein	SD	Sudan		
DE	Germany	LK	Sri Lanka	SE	Sweden		
DK	Denmark	LR	Liberia	SG	Singapore		
EE	Estonia						

PROPYLENE POLYMERS INCORPORATING MACROMERS

This application is based on U.S. provisional application 60/069,189, filed 12/10/97.

5

FIELD OF THE INVENTION

The present invention relates to propylene polymers incorporating macromers and a method for the preparation of branched polypropylene utilizing chiral, stereorigid transition metal catalyst compounds.

10

BACKGROUND OF THE INVENTION

Polypropylene and related polymers are known to have low melt strength. This is a significant deficiency in key application areas such as thermoforming and blow molding. Polyethylene on the other hand is used extensively in blown film applications requiring good melt strength. The limitations in the melt strength of polypropylenes show up as excess sag in sheet extrusion, rapid thinning of walls in parts thermoformed in the melt phase, low draw-down ratios in extrusion coating, poor bubble formation in extrusion foam materials, and relative weakness in large-part blow molding. Thus, it would be highly desirable to produce polypropylene and related polymers having enhanced melt strength as well as commercially valuable processability.

15
20

Increasing the melt strength of polymers such as polypropylene has been an industrial goal for well over ten years, however, success has been limited. The desirable properties that have made low density polyethylene commercially successful are attributed in large part to high melt strength and excellent processability. Both of these properties are attributed to the presence of long chain branching which is thought to occur under high pressure polymerization conditions.

25

There has been some success in increasing the melt strength of polypropylene. For example, EP 190 889 A2 discloses high energy irradiation of polypropylene to create what is believed to be polypropylene having substantial free-end long branches of propylene units. EP 384 431 discloses the use of

30

peroxide decomposition of polypropylene in the substantial absence of oxygen to obtain a similar product.

Other attempts to improve the melt properties of polypropylene include U.S. Patent 5,541,236, which introduces long chain branching by bridging two PP
5 backbones to form H-type polymers, and U.S. Patent 5,514,761, which uses dienes incorporated in the backbones to achieve a similar effect. However, it is difficult to avoid cross-linking and gel formation in such processes.

Thus, there is still a need for propylene polymers having improved melt strength and good processability.

SUMMARY OF THE INVENTION

10 The present invention meets that need by providing a polyolefin composition consisting essentially of isotactic polypropylene and, optionally, one or more comonomers, wherein the total comonomer content of the polyolefin composition is from 0 to 20 mole percent, and further, wherein the weight average
15 branching index g' for the lower molecular weight region of the polyolefin composition is less than 0.93. Additionally, a process is provided for producing a polyolefin composition comprising:

- a) contacting, in solution, at a temperature from about 90°C to about 120°C, propylene monomers with a catalyst composition
20 comprising a first chiral, stereorigid transition metal catalyst compound capable of producing isotactic polypropylene;
- b) copolymerizing the product of a) with propylene and, optionally, one or more copolymerizable monomers, in a polymerization reactor under suitable polypropylene polymerization conditions
25 using a second chiral, stereorigid transition metal catalyst capable of producing isotactic polypropylene; and
- c) recovering a branched olefin polymer.

BRIEF DESCRIPTION OF THE DRAWINGS

Figure 1 is a graphic illustration of the relationship between the weight average branching index g' and the molecular weight for the polymer product produced in Example 2.

5 Figure 2 is a graphic illustration of the relationship between the weight average branching index g' and the molecular weight for the polymer product produced in Example 3.

Figure 3 is a graphic illustration of the relationship between the weight average branching index g' and the molecular weight for the polymer product produced in Comparative Example 4.

10 Figure 4 is a graphic illustration of the complex viscosity vs. shear rate curve for the polymer products produced in Example 3 and Comparative Example 4.

DETAILED DESCRIPTION OF THE INVENTION

15 The polyolefin compositions of this invention are comprised of branched polymers wherein both the polymer backbone and polymeric sidechains are derived from propylene polymerized under coordination or insertion conditions with activated transition metal organometallic catalyst compounds. The sidechains are stereospecific (either isotactic or syndiotactic) polypropylene which exhibit crystalline, semi-crystalline or glassy properties suitable for hard phase domains in accordance with the art understood meaning of those terms, and are attached to a polymeric backbone that is also crystalline. The backbone is composed of stereospecific polypropylene and, optionally, one or more comonomers. Preferably, the backbone and the sidechains are isotactic polypropylene. These compositions are useful as thermoforming resins and exhibit improved processability over current polypropylene compositions.

The Macromer Sidechains

25 The sidechains are polypropylene macromers, which can be prepared under solution polymerization conditions with metallocene catalysts suitable for preparing either of isotactic or syndiotactic polypropylene. A preferred reaction process for

30

propylene macromers having high levels of terminal vinyl unsaturation is described in co-pending U.S. application 60/067,783 filed 12/10/97. Typically used catalysts are stereorigid, chiral or asymmetric, bridged metallocenes. See, for example, U.S. patent 4,892,851, U.S. patent 5,017,714, U.S. patent 5,132,281, U.S. Patent 5,132,381, U.S. Patent 5,155,080, U.S. patent 5,296,434, U.S. patent 5,278,264, U.S. patent 5,304,614, U.S. patent 5,510,502, WO-A-(PCT/US92/10066) WO-A-93/19103, EP-A2-0 577 581, EP-A1-0 578 838, and academic literature "The Influence of Aromatic Substituents on the Polymerization Behavior of Bridged Zirconocene Catalysts", Spaleck, W., *et al*, *Organometallics* 1994, 13, 954-963, and "ansa-Zirconocene Polymerization Catalysts with Annelated Ring Ligands-Effects on Catalytic Activity and Polymer Chain Lengths", Brinzinger, H., *et al*, *Organometallics* 1994, 13, 964-970, and documents referred to therein.

Preferably, the stereorigid transition metal catalyst compound is selected from the group consisting of bridged bis(indenyl) zirconocenes or hafnocenes or azulenyl ligand equivalents thereof. In a preferred embodiment, the transition metal catalyst compound is a dimethylsilyl-bridged bis(indenyl) zirconocene or hafnocene. More preferably, the transition metal catalyst compound is dimethylsilyl bis(2-methyl-4-phenylindenyl) zirconium or hafnium dichloride or dimethyl. In another preferred embodiment, the transition metal catalyst is a dimethylsilyl-bridged bis(indenyl) hafnocene such as dimethylsilyl bis(indenyl)hafnium dimethyl or dichloride. The method for preparing propylene-based macromers having a high percentage of vinyl terminal bonds involves:

- a) contacting, in solution at a temperature from about 90°C to about 120°C, propylene, optionally a minor amount of copolymerizable monomer, with a catalyst composition containing the stereorigid, activated transition metal catalyst compound; and
- b) recovering isotactic or syndiotactic polypropylene chains having number average molecular weights of about 2,000 to about 50,000 Daltons.

Preferably, the solution comprises a hydrocarbon solvent such as toluene. Also, the propylene monomers are preferably contacted at a temperature from

95°C to 115°C. More preferably, a temperature from 100°C to 110°C is used. Most preferably, the propylene monomers are contacted at a temperature from 105°C to 110°C. The pressures of the reaction generally can vary from atmospheric to 345 MPa, preferably to 182 MPa. The reactions can be run
5 batchwise or continuously. Conditions for suitable slurry-type reactions will also be suitable and are similar to solution conditions, the polymerization typically being run in liquid propylene under pressures suitable to such.

Additionally the invention branched polyolefin composition can be prepared directly from the selected olefins concurrently in the presence of a mixed catalyst
10 system comprising at least one first transition metal olefin polymerization catalyst capable of preparing propylene copolymers having greater than 50% chain end-group unsaturation and at least one second transition metal olefin polymerization catalyst capable of incorporating the propylene homopolymer or copolymer
15 sidechains into said branched olefin copolymer. This *in situ* method can be practiced by any method that permits both preparation of isotactic polypropylene macromers having crystalline, semi-crystalline or glassy properties and copolymerization of the macromers with polypropylene and other comonomers such that a branched copolymer is prepared. Gas phase, slurry and solution
20 processes can be used under conditions of temperature and pressure known to be useful in such processes.

As used herein, "isotactic polypropylene" is defined as having at least 70% isotactic pentads according to analysis by ¹³C-NMR. "Highly isotactic polypropylene" is defined as having at least 90% isotactic pentads according to analysis by ¹³C-NMR. "Syndiotactic polypropylene" is defined as polypropylene
25 having at least 70% syndiotactic pentads according to analysis by ¹³C-NMR. Preferably, the macromers of the present invention are highly isotactic polypropylene.

The polypropylene macromers can have narrow or broad molecular weight distribution (Mw/Mn), for example, from 1.5 to 5, typically 1.7 to 3. Optionally,
30 mixtures of sidechains with different molecular weights may be used.

The number-average molecular weight (M_n) of the polypropylene macromers of the present invention typically ranges from greater than or equal to 2,000 Daltons to less than about 50,000 Daltons, preferably less than 40,000 Daltons, more preferably less than 30,000 Daltons, most preferably less than or equal to 20,000 Daltons. Preferably, the M_n of the polypropylene macromers of the present invention is greater than or equal to 5,000 Daltons, more preferably greater than or equal to 7,500 Daltons, most preferably greater than or equal to 10,000 Daltons. The number of sidechains is related to the M_n of the sidechains such that the total weight fraction of the polymeric backbone segments between and outside the incorporated sidechains is greater than 0.40, preferably greater than 0.5-0.6. Weight here is determined by gel permeation chromatography (GPC) and differential refractive index (DRI) measurements.

Preferably, the macromers of the present invention are made using solution-phase conditions. Preferred solvents for solution phase reactions are selected on the basis of polymer solubility, volatility and safety/health considerations. Non-polar alkanes or aromatics are preferred. More preferably, the solvent is aromatic. Most preferably, the solvent is toluene.

The Polyolefin Backbone

The polyolefin backbone of the present invention is composed of propylene monomers and, optionally, one or more comonomers. In one embodiment of the present invention, no comonomers are present in the polyolefin backbone, resulting in a polymer having an isotactic polypropylene backbone and stereospecific polypropylene sidechains. Preferably, the sidechains are isotactic polypropylene.

In another embodiment of the present invention, one or more comonomers are present in the backbone. Comonomers which are useful in the present invention include ethylene, C_4 - C_{20} α -olefins, and lower carbon number (C_3 - C_8) alkyl substituted analogs of the cyclic and styrenic olefins. Other copolymerizable monomers include geminally disubstituted olefins such as isobutylene, C_5 - C_{25} cyclic olefins such as cyclopentene, norbornene and alkyl-substituted norbornenes, and styrenic monomers such as styrene and alkyl substituted styrenes.

Comonomers are selected for use based on the desired properties of the polymer product and the metallocene employed will be selected for its ability to incorporate the desired amount of olefins.

When comonomers are used, they preferably comprise from 3 to 20 mole percent of the branched polyolefin composition. More preferably, the comonomers
5 comprise from 5 to 17 mole percent of the branched polyolefin composition.

In another embodiment of the present invention, the backbone of the present invention contains syndiotactic polypropylene and, optionally, one or more comonomers. Essentially all of the backbone can be syndiotactic, resulting in a
10 polymer having a syndiotactic polypropylene backbone and stereospecific polypropylene sidechains. Alternatively, the backbone can be a combination of syndiotactic and isotactic polypropylene with, optionally, one or more comonomers.

An unusual feature of the branched polyolefin of the present invention is the
15 presence of a significant amount of branching in the lower molecular weight range of the polymer. This branching results in improved melt strength, as well as other unique physical properties. In this case, the amount of branching is determined using the weight average branching index g' of the branched polyolefin. The weight average branching index g' is defined as $g' = [IV]_{br}/[IV]_{lin}|_{Mw}$. It is well
20 known in the art that as the g' value decreases, branching increases. See B.H. Zimm and W.H. Stockmayer, J. Chem. Phys. 17, 1301 (1949).

Preferably, the weight average branching index g' for the lower molecular weight region of the branched polyolefin of the present invention is less than 0.93. More preferably, the weight average branching index g' for the lower molecular
25 weight region of the branched polyolefin of the present invention is less than 0.90. Most preferably, the weight average branching index g' for the lower molecular weight region of the branched polyolefin of the present invention is less than 0.88.

With regard to the molecular weight distribution of the polyolefin composition of the present invention, the following definitions apply:

Lower molecular weight region: That portion of the polymer product which has a molecular weight which is less than the number average molecular weight of the total polymer product.

5 Higher molecular weight region: That portion of the polymer product which has a molecular weight which is more than the number average molecular weight of the total polymer product.

The mass of the backbone will typically comprise at least 40 wt% of the total polymer mass, that of the backbone and the sidechains together, so the backbone typically will have a nominal weight-average molecular weight (M_w)
10 weight of at least equal to or greater than about 100,000. The term nominal is used to indicate that direct measurement of M_w of the backbone is largely impossible but that characterization of the copolymer product will exhibit measurements of M_w that correlate to a close approximate weight of the polymeric
15 backbone inclusive only of the monoolefin mer derivatives and the insertion moieties of the sidebranches.

Catalysts

Catalysts which are useful for producing the branched polyolefin of the present invention include all catalysts which are capable of producing isotactic
20 polypropylene and incorporating significant quantities of the isotactic polypropylene macromers of the present invention. Preferably, metallocene catalysts are used.

As used herein "metallocene" refers generally to compounds represented by the formula $Cp_mMR_nX_q$ wherein Cp is a cyclopentadienyl ring which may be substituted, or derivative thereof which may be substituted, M is a Group 4, 5, or 6
25 transition metal, for example titanium, zirconium, hafnium, vanadium, niobium, tantalum, chromium, molybdenum and tungsten, R is a hydrocarbyl group or hydrocarboxy group having from one to 20 carbon atoms, X is a halogen, and $m=1-3$, $n=0-3$, $q=0-3$, and the sum of $m+n+q$ is equal to the oxidation state of the
30 transition metal.

Methods for making and using metallocenes are well known in the art. For example, metallocenes are detailed in United States Patent Nos. 4,530,914; 4,542,199; 4,769,910; 4,808,561; 4,871,705; 4,933,403; 4,937,299; 5,017,714; 5,057,475; 5,120,867; 5,278,119; 5,304,614; 5,324,800; 5,350,723; and 5,391,790.

Preferred metallocenes are those that are stereorigid and comprise a Group 4, 5, or 6 transition metal, biscyclopentadienyl derivative, preferably bis-indenyl metallocene components having the following general structure:

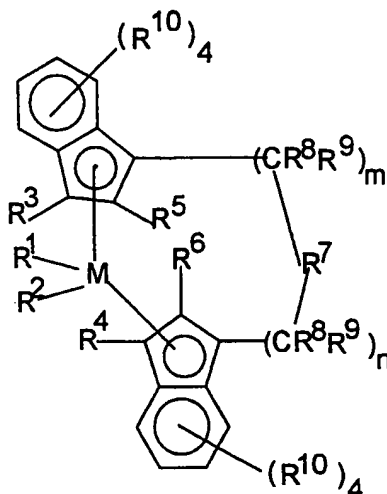

wherein M^1 is a metal of Group 4, 5, or 6 of the Periodic Table, for example titanium, zirconium, hafnium, vanadium, niobium, tantalum, chromium, molybdenum and tungsten, preferably, zirconium, hafnium and titanium, most preferably zirconium and hafnium;

R^1 and R^2 are identical or different, are one of a hydrogen atom, a C_1 - C_{10} alkyl group, preferably a C_1 - C_3 alkyl group, a C_1 - C_{10} alkoxy group, preferably a C_1 - C_3 alkoxy group, a C_6 - C_{10} aryl group, preferably a C_6 - C_8 aryl group, a C_6 - C_{10} aryloxy group, preferably a C_6 - C_8 aryloxy group, a C_2 - C_{10} alkenyl group, preferably a C_2 - C_4 alkenyl group, a C_7 - C_{40} arylalkyl group, preferably a C_7 - C_{10} arylalkyl group, a C_7 - C_{40} alkylaryl group, preferably a C_7 - C_{12} alkylaryl group, a

C₈-C₄₀ arylalkenyl group, preferably a C₈-C₁₂ arylalkenyl group, or a halogen atom, preferably chlorine;

R³ and R⁴ are hydrogen atoms;

R⁵ and R⁶ are identical or different, preferably identical, are one of a hydrogen atom, halogen atom, preferably a fluorine, chlorine or bromine atom, a C₁-C₁₀ alkyl group, preferably a C₁-C₄ alkyl group, which may be halogenated, a C₆-C₁₀ aryl group, which may be halogenated, preferably a C₆-C₈ aryl group, a C₂-C₁₀ alkenyl group, preferably a C₂-C₄ alkenyl group, a C₇-C₄₀ -arylalkyl group, preferably a C₇-C₁₀ arylalkyl group, a C₇-C₄₀ alkylaryl group, preferably a C₇-C₁₂ alkylaryl group, a C₈-C₄₀ arylalkenyl group, preferably a C₈-C₁₂ arylalkenyl group, a -NR₂¹⁵, -SR¹⁵, -OR¹⁵, -OSiR₃¹⁵ or -PR₂¹⁵ radical, wherein R¹⁵ is one of a halogen atom, preferably a chlorine atom, a C₁-C₁₀ alkyl group, preferably a C₁-C₃ alkyl group, or a C₆-C₁₀ aryl group, preferably a C₆-C₉ aryl group;

R⁷ is

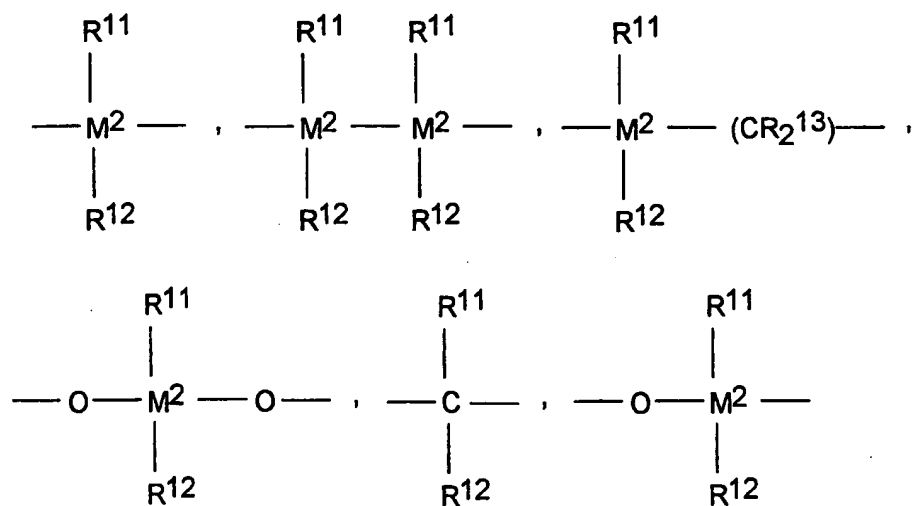

=BR¹¹, =AIR¹¹, -Ge-, -Sn-, -O-, -S-, =SO, =SO₂, =NR¹¹, =CO, PR¹¹, or =P(O)R¹¹;

wherein:

R¹¹, R¹² and R¹³ are identical or different and are a hydrogen atom, a halogen atom, a C₁-C₂₀ alkyl group, preferably a C₁-C₁₀ alkyl group, a C₁-C₂₀ fluoroalkyl group, preferably a C₁-C₁₀ fluoroalkyl group, a C₆-C₃₀ aryl group, preferably a C₆-C₂₀ aryl group, a C₆-C₃₀ fluoroaryl group, preferably a C₆-C₂₀ fluoroaryl group, a C₁-C₂₀ alkoxy group, preferably a C₁-C₁₀ alkoxy group, a C₂-C₂₀ alkenyl group, preferably a C₂-C₁₀ alkenyl group, a C₇-C₄₀ arylalkyl group, preferably a C₇-C₂₀ arylalkyl group, a C₈-C₄₀ arylalkenyl group, preferably a C₈-C₂₂ arylalkenyl group, a C₇-C₄₀ alkylaryl group, preferably a C₇-C₂₀ alkylaryl group or R¹¹ and R¹², or R¹¹ and R¹³, together with the atoms binding them, can form ring systems;

M² is silicon, germanium or tin, preferably silicon or germanium, most preferably silicon;

R⁸ and R⁹ are identical or different and have the meanings stated for R¹¹;

m and n are identical or different and are zero, 1 or 2, preferably zero or 1, m plus n being zero, 1 or 2, preferably zero or 1; and

the radicals R¹⁰ are identical or different and have the meanings stated for R¹¹, R¹² and R¹³. Two adjacent R¹⁰ radicals can be joined together to form a ring system, preferably a ring system containing from about 4-6 carbon atoms.

Alkyl refers to straight or branched chain substituents. Halogen (halogenated) is fluorine, chlorine, bromine or iodine atoms, preferably fluorine or chlorine.

Particularly preferred metallocenes are compounds of the structures:

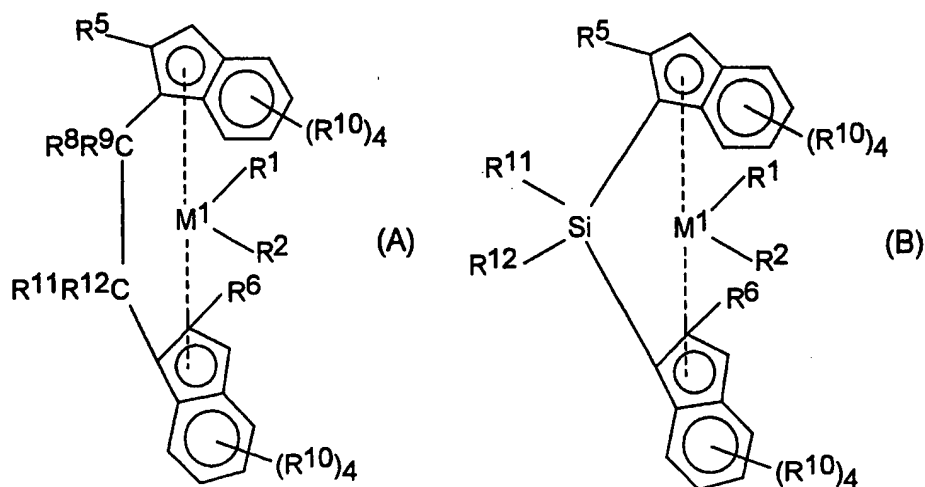

wherein:

M^1 is Zr or Hf, R^1 and R^2 are methyl or chlorine, and R^5 , R^6 , R^8 , R^9 , R^{10} ,
 5 R^{11} and R^{12} have the above-mentioned meanings.

The chiral metallocenes may be used as a racemate for the preparation of highly isotactic polypropylene polymers and copolymers. It is also possible to use the pure R or S form. An optically active polymer can be prepared with these pure stereoisomeric forms. Preferably the meso form of the metallocene is removed to ensure the center (i.e., the metal atom) provides stereoregular polymerization.
 10 Separation of the stereoisomers can be accomplished by known literature techniques. For special products it is also possible to use rac/meso mixtures.

Generally, the metallocenes are prepared by a multi-step process involving repeated deprotonations/metallations of the aromatic ligands and introduction of the bridge and the central atom by their halogen derivatives. The following reaction scheme illustrates this generic approach:

5

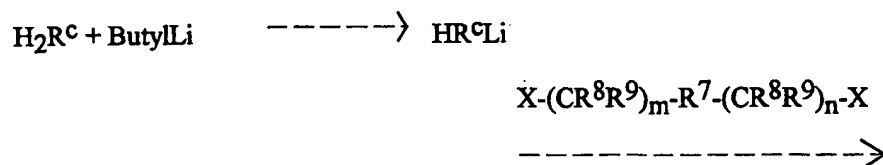

10

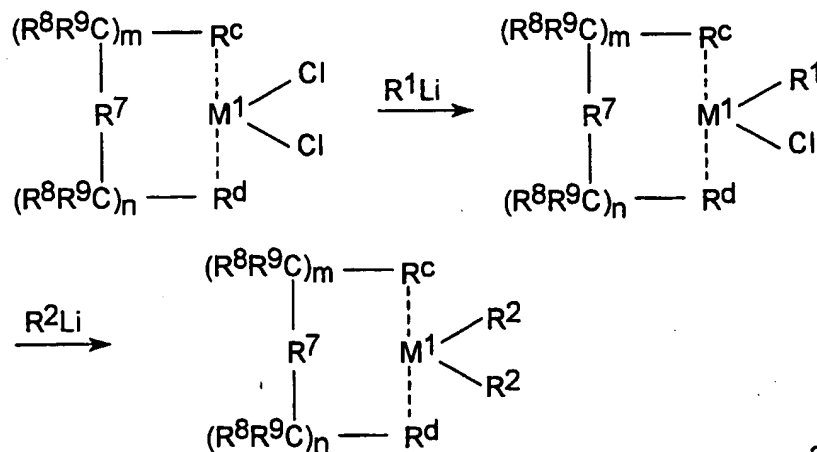
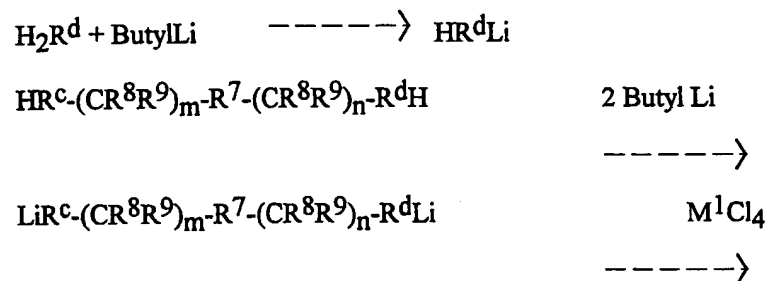

X = Cl, Br, I or O-tosyl;

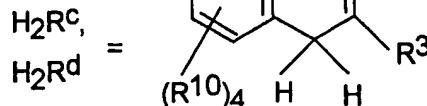

15

Additional methods for preparing metallocenes of the present invention are fully described in the *Journal of Organometallic Chem.*, volume 288, (1958), pages 63-67, and in EP-A- 320762, for preparation of the metallocenes described.

Illustrative but non-limiting examples of some preferred metallocenes include: Dimethylsilandiylbis(2-methyl-4-phenyl-1-indenyl)ZrCl₂
Dimethylsilandiylbis(2-methyl-4,5-benzoindenyl)ZrCl₂;
Dimethylsilandiylbis(2-methyl-4,6-diisopropylindenyl)ZrCl₂;
5 Dimethylsilandiylbis(2-ethyl-4-phenyl-1-indenyl)ZrCl₂;
Dimethylsilandiylbis(2-ethyl-4-naphthyl-1-indenyl)ZrCl₂,
Phenyl(Methyl)silandiylbis(2-methyl-4-phenyl-1-indenyl)ZrCl₂,
Dimethylsilandiylbis(2-methyl-4-(1-naphthyl)-1-indenyl)ZrCl₂,
Dimethylsilandiylbis(2-methyl-4-(2-naphthyl)-1-indenyl)ZrCl₂,
10 Dimethylsilandiylbis(2-methyl-indenyl)ZrCl₂,
Dimethylsilandiylbis(2-methyl-4,5-diisopropyl-1-indenyl)ZrCl₂,
Dimethylsilandiylbis(2,4,6-trimethyl-1-indenyl)ZrCl₂,
Phenyl(Methyl)silandiylbis(2-methyl-4,6-diisopropyl-1-indenyl)ZrCl₂,
1,2-Ethandiylbis(2-methyl-4,6-diisopropyl-1-indenyl)ZrCl₂,
15 1,2-Butandiylbis(2-methyl-4,6-diisopropyl-1-indenyl)ZrCl₂,
Dimethylsilandiylbis(2-methyl-4-ethyl-1-indenyl)ZrCl₂,
Dimethylsilandiylbis(2-methyl-4-isopropyl-1-indenyl)ZrCl₂,
Dimethylsilandiylbis(2-methyl-4-t-butyl-1-indenyl)ZrCl₂,
Phenyl(Methyl)silandiylbis(2-methyl-4-isopropyl-1-indenyl)ZrCl₂,
20 Dimethylsilandiylbis(2-ethyl-4-methyl-1-indenyl)ZrCl₂,
Dimethylsilandiylbis(2,4-dimethyl-1-indenyl)ZrCl₂,
Dimethylsilandiylbis(2-methyl-4-ethyl-1-indenyl)ZrCl₂,
Dimethylsilandiylbis(2-methyl- α -acenaphth-1-indenyl)ZrCl₂,
Phenyl(Methyl)silandiylbis(2-methyl-4,5-benzo-1-indenyl)ZrCl₂,
25 Phenyl(Methyl)silandiylbis(2-methyl-4,5-(methylbenzo)-1-indenyl)ZrCl₂,
Phenyl(Methyl)silandiylbis(2-methyl-4,5-(tetramethylbenzo)-1-indenyl)ZrCl₂,
Phenyl(Methyl)silandiylbis(2-methyl- α -acenaphth-1-indenyl)ZrCl₂,
1,2-Ethandiylbis(2-methyl-4,5-benzo-1-indenyl)ZrCl₂,
1,2-Butandiylbis(2-methyl-4,5-benzo-1-indenyl)ZrCl₂,

Dimethylsilandiylbis(2-methyl-4,5-benzo-1-indenyl)ZrCl₂,
1,2-Ethandiylbis(2,4,7-trimethyl-1-indenyl)ZrCl₂,
Dimethylsilandiylbis(2-methyl-1-indenyl)ZrCl₂,
1,2-Ethandiylbis(2-methyl-1-indenyl)ZrCl₂,
5 Phenyl(Methyl)silandiylbis(2-methyl-1-indenyl)ZrCl₂,
Diphenylsilandiylbis(2-methyl-1-indenyl)ZrCl₂,
1,2-Butandiylbis(2-methyl-1-indenyl)ZrCl₂,
Dimethylsilandiylbis(2-ethyl-1-indenyl)ZrCl₂,
Dimethylsilandiylbis(2-methyl-5-isobutyl-1-indenyl)ZrCl₂,
10 Phenyl(Methyl)silandiylbis(2-methyl-5-isobutyl-1-indenyl)ZrCl₂,
Dimethylsilandiylbis(2-methyl-5-t-butyl-1-indenyl)ZrCl₂,
Dimethylsilandiylbis(2,5,6-trimethyl-1-indenyl)ZrCl₂, and the like.

Some preferred metallocene catalyst components are described in detail in U.S. Patent Nos. 5,149,819, 5,243,001, 5,239,022, 5,296,434 and 5,276,208. In addition, the bis-amido and bis-arylamido transition metal catalysts of U.S. patent 15 5,318,935 and copending U.S. patent application 08/ 803,687, filed 2/24/97, and the α -diimine nickel catalyst complexes of WO 96/23010 can be useful in incorporating the macromers of the present invention into the backbone.

Most preferably, the catalyst used to produce the branched polyolefin of the present invention is a dimethylsilyl-bridged bis-indenyl zirconocene or hafnocene 20 such as dimethylsilyl bis(2-methyl-indenyl) ZrCl₂, dimethylsilyl bis(2-methyl-4-phenyl-1-indenyl) ZrCl₂, dimethylsilyl bis(2-methyl-4-(1-naphthyl)-1-indenyl) ZrCl₂, or dimethylsilyl bis(indenyl)hafnium dimethyl.

Preferably, the catalysts used to produce the syndiotactic polypropylene backbone of the present invention are those disclosed in U.S. Patents 4,892,851, 25 5,155,080, and 5,132,381.

The terms "cocatalyst" and "activator" are used herein interchangeably and are defined to be any compound or component which can activate a bulky ligand transition metal compound or a metallocene, as defined above. Alumoxane may be 30 used as an activator. There are a variety of methods for preparing alumoxane, non-

limiting examples of which are described in U.S. Patent No. 4,665,208, 4,952,540, 5,091,352, 5,206,199, 5,204,419, 4,874,734, 4,924,018, 4,908,463, 4,968,827, 5,308,815, 5,329,032, 5,248,801, 5,235,081, 5,157,137, 5,103,031 and EP-A-0 561 476, EP-B1-0 279 586, EP-A-0 594 218 and WO 94/10180. It may be
5 preferable to use a visually clear methylalumoxane. A cloudy or gelled alumoxane can be filtered to produce a clear solution or clear alumoxane can be decanted from the cloudy solution.

It is also within the scope of this invention to use ionizing activators, neutral or ionic, or compounds such as tri(n-butyl)ammonium
10 tetrakis(pentafluorophenyl)boron, which ionize the neutral metallocene compound. Such ionizing compounds may contain an active proton, or some other cation associated with but not coordinated or only loosely coordinated to the remaining ion of the ionizing compound. Combinations of activators are also contemplated by the invention, for example, alumoxane and ionizing activators in combinations, see
15 for example, WO 94/07928.

Descriptions of ionic catalysts for coordination polymerization comprised of metallocene cations activated by non-coordinating anions appear in the early work in EP-A-0 277 003, EP-A-0 277 004 and US patent 5,198,401 and
20 WO-A-92/00333. These teach a preferred method of preparation wherein metallocenes (bisCp and monoCp) are protonated by an anion precursor such that an alkyl/hydride group is abstracted from a transition metal to make it both cationic and charge-balanced by the non-coordinating anion.

The term "noncoordinating anion" means an anion which either does not coordinate to said cation or which is only weakly coordinated to said cation
25 thereby remaining sufficiently labile to be displaced by a neutral Lewis base. "Compatible" noncoordinating anions are those which are not degraded to neutrality when the initially formed complex decomposes. Further, the anion will not transfer an anionic substituent or fragment to the cation so as to cause it to form a neutral four coordinate metallocene compound and a neutral by-product
30 from the anion. Noncoordinating anions useful in accordance with this invention are those which are compatible, stabilize the metallocene cation in the sense of

balancing its ionic charge in a +1 state, yet retain sufficient lability to permit displacement by an ethylenically or acetylenically unsaturated monomer during polymerization.

The use of ionizing ionic compounds not containing an active proton but capable of producing the both the active metallocene cation and a noncoordinating anion is also known. See, EP-A-0 426 637 and EP-A- 0 573 403. An additional method of making the ionic catalysts uses ionizing anion pre-cursors which are initially neutral Lewis acids but form the cation and anion upon ionizing reaction with the metallocene compounds, for example the use of tris(pentafluorophenyl) boron. See EP-A-0 520 732. Ionic catalysts for addition polymerization can also be prepared by oxidation of the metal centers of transition metal compounds by anion pre-cursors containing metallic oxidizing groups along with the anion groups, see EP-A-0 495 375.

Where the metal ligands include halogen moieties (for example, bis-cyclopentadienyl zirconium dichloride) which are not capable of ionizing abstraction under standard conditions, they can be converted via known alkylation reactions with organometallic compounds such as lithium or aluminum hydrides or alkyls, alkylaluminum compounds, Grignard reagents, etc. See EP-A-0 500 944 and EP-A1-0 570 982 for *in situ* processes describing the reaction of alkyl aluminum compounds with dihalo-substituted metallocene compounds prior to or with the addition of activating anionic compounds.

Support Materials

The metallocenes described herein are preferably supported using a porous particulate material, such as for example, talc, inorganic oxides, inorganic chlorides and resinous materials such as polyolefin or polymeric compounds.

The most preferred support materials are porous inorganic oxide materials, which include those from the Periodic Table of Elements of Groups 2, 3, 4, 5, 13 or 14 metal oxides. Silica, alumina, silica-alumina, and mixtures thereof are particularly preferred. Other inorganic oxides that may be employed either alone or in combination with the silica, alumina or silica-alumina are magnesia, titania, zirconia, and the like.

Preferably the support material is porous silica which has a surface area in the range of from about 10 to about 700 m²/g, a total pore volume in the range of from about 0.1 to about 4.0 cc/g and an average particle size in the range of from about 10 to about 500 μm. More preferably, the surface area is in the range of from about 50 to about 500 m²/g, the pore volume is in the range of from about 0.5 to about 3.5 cc/g and the average particle size is in the range of from about 20 to about 200 μm. Most preferably the surface area is in the range of from about 100 to about 400 m²/g, the pore volume is in the range of from about 0.8 to about 3.0 cc/g and the average particle size is in the range of from about 30 to about 100 μm. The average pore size of typical porous support materials is in the range of from about 10 to about 1000Å. Preferably, a support material is used that has an average pore diameter of from about 50 to about 500Å, and most preferably from about 75 to about 350Å. It may be particularly desirable to dehydrate the silica at a temperature of from about 100°C to about 800°C anywhere from about 3 to about 24 hours.

The metallocenes, activator and support material may be combined in any number of ways. Suitable support techniques are described in U. S Patent Nos. 4,808,561 and 4,701,432 . Preferably the metallocenes and activator are combined and their reaction product supported on the porous support material as described in U. S. Patent No. 5,240,894 and WO 94/ 28034, WO 96/00243, and WO 96/00245. Alternatively, the metallocenes may be preactivated separately and then combined with the support material either separately or together. If the metallocenes are separately supported, then preferably, they are dried then combined as a powder before use in polymerization.

Regardless of whether the metallocene and activator are separately pre-contacted or whether the metallocene and activator are combined at once, the total volume of reaction solution applied to porous support is preferably less than about 4 times the total pore volume of the porous support, more preferably less than about 3 times the total pore volume of the porous support and even more preferably in the range of from more than about 1 to less than about 2.5 times the

total pore volume of the porous support. Procedures for measuring the total pore volume of porous support are well known in the art. The preferred method is described in Volume 1, *Experimental Methods in Catalyst Research*, Academic Press, 1968, pages 67-96.

5 Methods of supporting ionic catalysts comprising metallocene cations and noncoordinating anions are described in WO 91/09882, WO 94/03506, WO 96/04319 and U.S. patent 5,643,847. The methods generally comprise either physical adsorption on traditional polymeric or inorganic supports that have been largely dehydrated and dehydroxylated, or using neutral anion precursors that are
10 sufficiently strong Lewis acids to activate retained hydroxy groups in silica containing inorganic oxide supports such that the Lewis acid becomes covalently bound and the hydrogen of the hydroxy group is available to protonate the metallocene compounds.

 The supported catalyst system may be used directly in polymerization or the
15 catalyst system may be prepolymerized using methods well known in the art. For details regarding prepolymerization, see United States Patent Nos. 4,923,833 and 4,921,825, EP 0 279 863 and EP 0 354 893.

Polymerization Processes

 The branched polyolefin of the present invention may be produced using
20 the catalysts described above in any process including gas, slurry or solution phase or high-pressure autoclave processes. (As used herein, unless differentiated, "polymerization" includes copolymerization and "monomer" includes comonomer.) Additionally, combinations of the above reactor types in multiple, series reactors and/or multiple reaction conditions and/or multiple catalyst configurations are
25 explicitly intended. Preferably, a gas or slurry phase process is used, most preferably a bulk liquid propylene polymerization process is used.

 In the preferred embodiment, this invention is directed toward the bulk liquid polymerization and copolymerization of propylene in a slurry or gas phase polymerization process, particularly a slurry polymerization process. Another
30 embodiment involves copolymerization reactions of propylene with one or more comonomers. Such comonomers include alpha-olefin monomers having from 4 to

20 carbon atoms, preferably 4-12 carbon atoms, for example alpha-olefin comonomers of ethylene, butene-1, pentene-1, 4-methylpentene-1, hexene-1, octene-1, decene-1. Other suitable comonomers include geminally disubstituted monomers, C₅-C₂₅ cyclic olefins such as cyclopentene or norbornene, styrenic olefins such as styrene, and lower carbon number (C₃-C₈) alkyl substituted analogs of the cyclic and styrenic olefins. In addition, comonomers such as polar vinyl, diolefins such as dienes, for example, 1,3-butadiene, 1,4-hexadiene, norbornadiene or vinylnorbornene, acetylene and aldehyde monomers are suitable.

Typically in a gas phase polymerization process a continuous cycle is employed wherein one part of the cycle of a reactor, a cycling gas stream, otherwise known as a recycle stream or fluidizing medium, is heated in the reactor by the heat of polymerization. The recycle stream usually contains one or more monomers continuously cycled through a fluidized bed in the presence of a catalyst under reactive conditions. This heat is removed in another part of the cycle by a cooling system external to the reactor. The recycle stream is withdrawn from the fluidized bed and recycled back into the reactor. Simultaneously, polymer product is withdrawn from the reactor and new or fresh monomer is added to replace the polymerized monomer. (See for example U.S. Patent Nos. 4,543,399; 4,588,790; 5,028,670; 5,352,749; 5,405,922, and 5,436,304).

A slurry polymerization process generally uses pressures in the range of from about 1 to about 500 atmospheres or even greater and temperatures in the range of from -60°C to about 280°C. In a slurry polymerization, a suspension of solid, particulate polymer is formed in a liquid or supercritical polymerization medium to which propylene and comonomers and often hydrogen along with catalyst are added. The liquid employed in the polymerization medium can be, for example, an alkane or a cycloalkane. The medium employed should be liquid under the conditions of polymerization and relatively inert such as hexane and isobutane. In the preferred embodiment, propylene serves as the polymerization diluent and the polymerization is carried out using a pressure of from about 200

kPa to about 7,000 kPa at a temperature in the range of from about 50°C to about 120°C.

The periods of time for each stage will depend upon the catalyst system, comonomer and reaction conditions. In general, propylene should be homopolymerized for a time period sufficient to yield a composition having from about 10 to about 90 weight percent homopolymer based on the total weight of the polymer, preferably from about 20 to about 80 weight percent, even more preferably from about 30 to about 70 homopolymer weight percent based on the total weight of the polymer.

The above-described temperatures, reaction times and other conditions are considered suitable polypropylene polymerization conditions for the purposes of this invention.

The polymerization may be conducted in batch or continuous mode and the entire polymerization may take place in one reactor or, preferably, the polymerization may be carried out in a series of reactors. If reactors in series are used, then the comonomer may be added to any reactor in the series, however, preferably, the comonomer is added to the second or subsequent reactor.

Hydrogen may be added to the polymerization system as a molecular weight regulator in the first and/or subsequent reactors depending upon the particular properties of the product desired and the specific metallocenes used. When metallocenes having different hydrogen responses are used, the addition of hydrogen will affect the molecular weight distribution of the polymer product accordingly. A preferred product form is to have the comonomer be present in the high molecular weight species of the total polymer composition to provide a favorable balance of good film stretchability without breaking, coupled with low extractables, low haze and good moisture barrier in the film. Accordingly in this preferred case, the same or lower levels of hydrogen are utilized during copolymerization as were used during polymerization in the second or subsequent reactor.

For both polypropylene macromer product and branched polyolefin preparation, it is known that many methods and permutations of the ordering of

addition of macromer and monomer species to the reactor are possible, some more advantageous than others. For example, it is widely known in the art that preactivation of the metallocene with alumoxane before addition to a continuous solution-phase reactor yields higher activities than continuous addition of
5 metallocene and activator in two separate streams. Furthermore, it may be advantageous to control precontacting time to maximize catalyst effectiveness, e.g., avoiding excessive aging of the activated catalyst composition.

It is preferable to use the isotactic polypropylene macromers such that they are promptly functionalized or copolymerized after being prepared. The highly
10 reactive vinyl groups appear to be susceptible to by-product reactions with adventitious impurities and, even, dimerization or addition reactions with other unsaturated group-containing polymeric chains. Thus maintaining in a cooled, inert environment after preparation and prompt subsequent use will optimize the effectiveness of the use of the polypropylene macromer product. A continuous
15 process utilizing series reactors, or parallel reactors will thus be effective, the polypropylene macromer product being prepared in one and continuously introduced into the other.

INDUSTRIAL UTILITY

The branched polyolefin polymers of the present invention exhibit improved
20 melt strength and shear thinning characteristics to standard propylene copolymers. This results in improved processability of the polymers, e.g. increased shear thinning and high output for a constant energy input. These characteristics will result in improved processing in blow molding and thermoforming operations. For example, in thermoforming operations sag will be decreased and power
25 consumption will be lowered in the extruders.

In order that the invention may be more readily understood, reference is made to the following examples, which are intended to illustrate the invention but not to limit the scope thereof.

EXAMPLES

General

All polymerizations were performed in a 2-liter Zipperclave reactor equipped with a water jacket for temperature control. Liquids were measured into
5 the reactor using calibrated sight glasses. High purity (>99.5%) toluene was purified by passing first through basic alumina activated at high temperature in nitrogen, followed by molecular sieve activated at high temperature in nitrogen. Propylene was purified by passing through activated basic alumina and molecular sieves. Methylalumoxane (MAO, 10% in toluene) was received from Albemarle
10 Inc. in stainless steel cylinders, divided into 1-liter glass containers, and stored in a laboratory glove-box at ambient temperature.

Propylene was measured into the reactor through a calibrated container. To ensure the reaction medium was well mixed, a flat-paddle stirrer rotating at 750 rpm was used.

Reactor Preparation

The reactor was first cleaned by heating to 150 °C in toluene to dissolve any polymer residues, then cooled and drained. Next, the reactor was heated using jacket water at 110 °C and the reactor was purged with flowing nitrogen for a period of ~30 minutes. Before reaction, the reactor was further purged using 3
20 nitrogen pressurize/vent cycles (to 100 psi). The cycling served two purposes: (1) to thoroughly penetrate all dead ends such as pressure gauges to purge fugitive contaminants and (2) to pressure test the reactor.

Catalysts

All catalyst preparations were performed in an inert atmosphere with <1.5
25 ppm H₂O content. The catalyst systems used in the synthesis of macromer was dimethylsilyl bis(2-methyl-4-phenylindenyl) zirconium dichloride. The dimethylsilyl bis(2-methyl-4-phenylindenyl) zirconium dichloride was activated with MAO. To maximize solubility of the metallocene, toluene was used as a solvent. The catalyst as added to a stainless steel tube by pipette and transferred to the reactor.

Example 1

The synthesis of polypropylene macromer was conducted in a 2-liter autoclave reactor. The reactor was charged with toluene (1 L), propylene (150 mL), and triisobutylaluminum (2.0 mL of 1M solution in toluene). The reactor was heated to 105 °C and equilibrated for 5 min. Then 2 mg of dimethylsilyl bis(2-methyl-4-phenylindenyl) zirconium dichloride and 1 mL of MAO (10wt% in toluene) were injected using a catalyst tube. After 15 min, the reactor was cooled to 25 °C and vented. Methanol (500 mL) was added to the polymer solution to precipitate the polymer. The polymer was collected by filtration, and dried in a vacuum oven for 12 hours. The polymer product had an Mn of 13,000 and a molecular weight distribution of 1.92.

Example 2

A 2-liter reactor was charged with toluene (1 L), propylene (150 mL), 10 g of the polypropylene macromer from Example 1 and Triisobutylaluminum (2.0 mL of 1M solution in toluene). The reactor was heated to 55°C and equilibrated for 5 min. Then 2 mg of dimethylsilyl bis(2-methyl-4-phenylindenyl) zirconium dichloride activated in 5 mL of toluene and 1 mL of MAO (10wt% in toluene) was injected using a catalyst tube. After 15 min, the reactor was cooled to 25°C and vented. The polymer was collected by filtration and dried in a vacuum oven (80°C) for 12 hours. Yield: 77 g.

Example 3

A 2-liter autoclave reactor was charged with toluene (1 L), propylene (150 mL), 20 g of the polypropylene macromer from Example 1 and Triisobutylaluminum (2.0 mL of 1M solution in toluene). The reactor was heated to 55°C and equilibrated for 5 min. Then 2 mg of dimethylsilyl bis(2-methyl-4-phenylindenyl) zirconium dichloride activated in 5 mL of toluene and 1 mL of MAO (10wt% in toluene) was injected using a catalyst tube. After 15 min, the reactor was cooled to 25°C and vented. The polymer was collected by filtration and dried in a vacuum oven (80°C) for 12 hours. Yield: 86 g.

Comparative Example 4

A 2-liter reactor was charged with toluene (1 L), propylene (150 mL), and Triisobutylaluminum (2.0 mL of 1M solution in toluene). The reactor was heated to 55°C and equilibrated for 5 min. Then 2 mg of dimethylsilyl bis(2-methyl-4-phenylindenyl) zirconium dichloride activated in 5 mL of toluene and 1 mL of MAO (10wt% in toluene) was injected using a catalyst tube. After 15 min, the reactor was cooled to 25°C and vented. The polymer was collected by filtration and dried in a vacuum oven (80°C) for 12 hours. Yield: 71 g.

Product Characterization

Some general characterization data for the polymers made in the Examples 2, 3 and Comparative Example 4 are listed in Table 1. The polymer product samples were analyzed by gel permeation chromatography using a Waters 150C high temperature system equipped with a DRI Detector, Showdex AT-806MS column and operating at a system temperature of 145°C. The solvent used was 1,2,4-trichlorobenzene, from which polymer sample solutions of 1.5 mg/ml concentration were prepared for injection. The total solvent flow rate was 1 ml/minute and the injection size was 300 microliters. After elution of the polymer samples, the resulting chromatograms were analyzed using the Waters Expert Fuse program to calculate the molecular weight distribution and one or more of M_n , M_w and M_z averages. The melting point of the polymer product samples was determined on a DSC 2910 Differential Scanning Calorimeter (TA Instruments). The reported melting points were recorded at second melt with a temperature ramp of 2 - 10 °C/min. The percentage of polypropylene macromer in the polymer samples was calculated by mass balance.

Table 1**GPC Molecular Weight and Number Summary**

Example	Mn	Mw	MWD	Tm (°C)	% Macromer
2	50,195	218,372	4.35	156.7	6.5
3	46,233	248,922	5.38	154.5	11.5
Comp. 4	61,350	262,234	4.27	158.7	0

GPC/Viscosity analysis was used to measure the incorporation of polypropylene macromer and the branch level in the polymer products of Examples 2, 3 and Comparative Example 4. The molecular weight of the polymers was measured by a Waters 150-C ALC/GPC and the intrinsic viscosity of the polymers in 1,2,4-trichlorobenzene was measured at each molecular weight in the GPC trace using a on-line differential viscometer at 135°C. The weight average branching index g' is defined as $g' = [IV]_{br}/[IV]_{lin}|_{Mw}$. As shown in Figs. 1 and 2, the g' values of the polymers incorporating macromers are substantially below 1, indicating extensive branches in these polymers. Fig. 3, on the other hand, shows that the polymer produced without macromers has g' values around 1 in the lower molecular weight region. This indicates very little or no branching of the lower molecular weight portion of the polymer product.

Figure 4 shows a complex viscosity vs. shear rate curve for the polymers produced in Example 3 and Comparative Example 4. Example 3 demonstrates a steeper curve than Comparative Example 4. A steeper curve correlates to improved shear thinning performance as the viscosity reduces more rapidly at high shear rates. Therefore, the polymer product which was produced using macromers demonstrates improved processability over a polymer which was produced without the use of macromers.

While certain representative embodiments and details have been shown for the purposes of illustrating the invention, it will be apparent to those skilled in the art that various changes in the process and products disclosed herein may be made without departing from the scope of the invention, which is defined in the appended claims.

CLAIMS

1. A polyolefin composition consisting essentially of isotactic polypropylene and, optionally, one or more comonomers, wherein the total comonomer content of said polyolefin composition is from 0 to 20 mole percent, and further, wherein the weight average branching index g' for the lower molecular weight region of said polyolefin composition is less than 0.93.
2. The composition of claim 1 wherein the weight average branching index g' for the lower molecular weight region of said polyolefin composition is less than 0.90.
3. The composition of claim 1 wherein no comonomers are present.
4. The composition of claim 1 wherein said one or more comonomers are selected from the group consisting of ethylene, C₄-C₂₀ α -olefins, geminally disubstituted monomers, C₅-C₂₅ cyclic olefins, C₅-C₂₅ styrenic olefins, and lower carbon number (C₃-C₈) alkyl substituted analogs of the cyclic and styrenic olefins.
5. The composition of claim 4 wherein said one or more comonomers comprise from 3 to 20 mole percent of said polyolefin composition.
6. The composition of claim 4 wherein said one or more comonomers comprise from 5 to 17 mole percent of said polyolefin composition.
7. A polypropylene composition produced by the process comprising:
 - a) contacting, in solution, at a temperature from 90°C to 120°C, propylene monomers with a catalyst composition comprising a first chiral, stereorigid transition metal catalyst compound capable of producing isotactic polypropylene;

- 5 b) copolymerizing the product of a) with propylene and, optionally, one or more copolymerizable monomers, in a polymerization reactor under suitable polypropylene polymerization conditions using a second chiral, stereorigid transition metal catalyst capable of producing isotactic polypropylene; and
- c) recovering a branched olefin polymer.

8. The composition of claim 7 wherein step a) is conducted by a process in which said propylene monomers are contacted with said first chiral, stereorigid transition metal catalyst compound activated by an alumoxane cocatalyst or non-coordinating anion precursor.

10

9. The composition of claim 8 wherein step b) is conducted in a separate reaction by solution, slurry or gas phase polymerization.

15

10. The composition of claim 7 wherein step a) and step b) are conducted concurrently.

11. The composition of claim 7 wherein said propylene monomers in step a) are contacted at a temperature from 100°C to 110°C.

20

12. The composition of claim 7 wherein said first chiral, stereorigid transition metal catalyst compound is selected from the group consisting of dimethylsilyl-bridged bis-indenyl zirconocenes or hafnocenes.

25

13. The composition of claim 7 wherein said first chiral, stereorigid transition metal catalyst compound is a dimethylsilyl-bridged bis-indenyl zirconocene.

14. The composition of claim 13 wherein said first chiral, stereorigid transition metal catalyst compound further comprises an alumoxane.

30

15. The composition of claim 7 wherein said first chiral, stereorigid transition metal catalyst compound is dimethylsilyl bis(2-methyl-4-phenylindenyl) zirconium dichloride.
- 5 16. The composition of claim 7 wherein said isotactic polypropylene produced in step a) have number average molecular weights of from 7,500 Daltons to 30,000 Daltons.
- 10 17. The composition of claim 7 wherein said isotactic polypropylene produced in step a) have number average molecular weights of from 10,000 Daltons to 20,000 Daltons.
18. A process for producing a polyolefin composition comprising:
- 15 a) contacting, in solution, at a temperature from 90°C to 120°C, propylene monomers with a catalyst composition comprising a first chiral, stereorigid transition metal catalyst compound capable of producing isotactic polypropylene;
- 20 b) copolymerizing the product of a) with propylene and, optionally, one or more copolymerizable monomers, in a polymerization reactor under suitable polypropylene polymerization conditions using a second chiral, stereorigid transition metal catalyst capable of producing isotactic polypropylene; and
- c) recovering a branched olefin polymer.
- 25 19. The process of claim 18 wherein step a) is conducted by a process in which said propylene monomers are contacted with said first chiral, stereorigid transition metal catalyst compound activated by an alumoxane cocatalyst or non-coordinating anion precursor.
- 30 20. The process of claim 19 wherein step b) is conducted in a separate reaction by solution, slurry or gas phase polymerization.

21. The process of claim 18 wherein step a) and step b) are conducted concurrently.
- 5 22. The process of claim 18 wherein said propylene monomers in step a) are contacted at a temperature from 100°C to 110°C.
23. The process of claim 18 wherein said first chiral, stereorigid transition metal catalyst compound is selected from the group consisting of dimethylsilyl-bridged bis-indenyl zirconocenes or hafnocenes.
- 10
24. The process of claim 18 wherein said first chiral, stereorigid transition metal catalyst compound is a dimethylsilyl-bridged bis-indenyl zirconocene.
- 15 25. The process of claim 24 wherein said first chiral, stereorigid transition metal catalyst compound further comprises an alumoxane.
26. The process of claim 18 wherein said first chiral, stereorigid transition metal catalyst compound is dimethylsilyl bis(2-methyl-4-phenylindenyl) zirconium dichloride.
- 20
27. The process of claim 18 wherein said isotactic polypropylene produced in step a) have number average molecular weights of from 7,500 Daltons to 30,000 Daltons.
- 25
28. The process of claim 18 wherein said isotactic polypropylene produced in step a) have number average molecular weights of from 10,000 Daltons to 20,000 Daltons.

FIG. 1

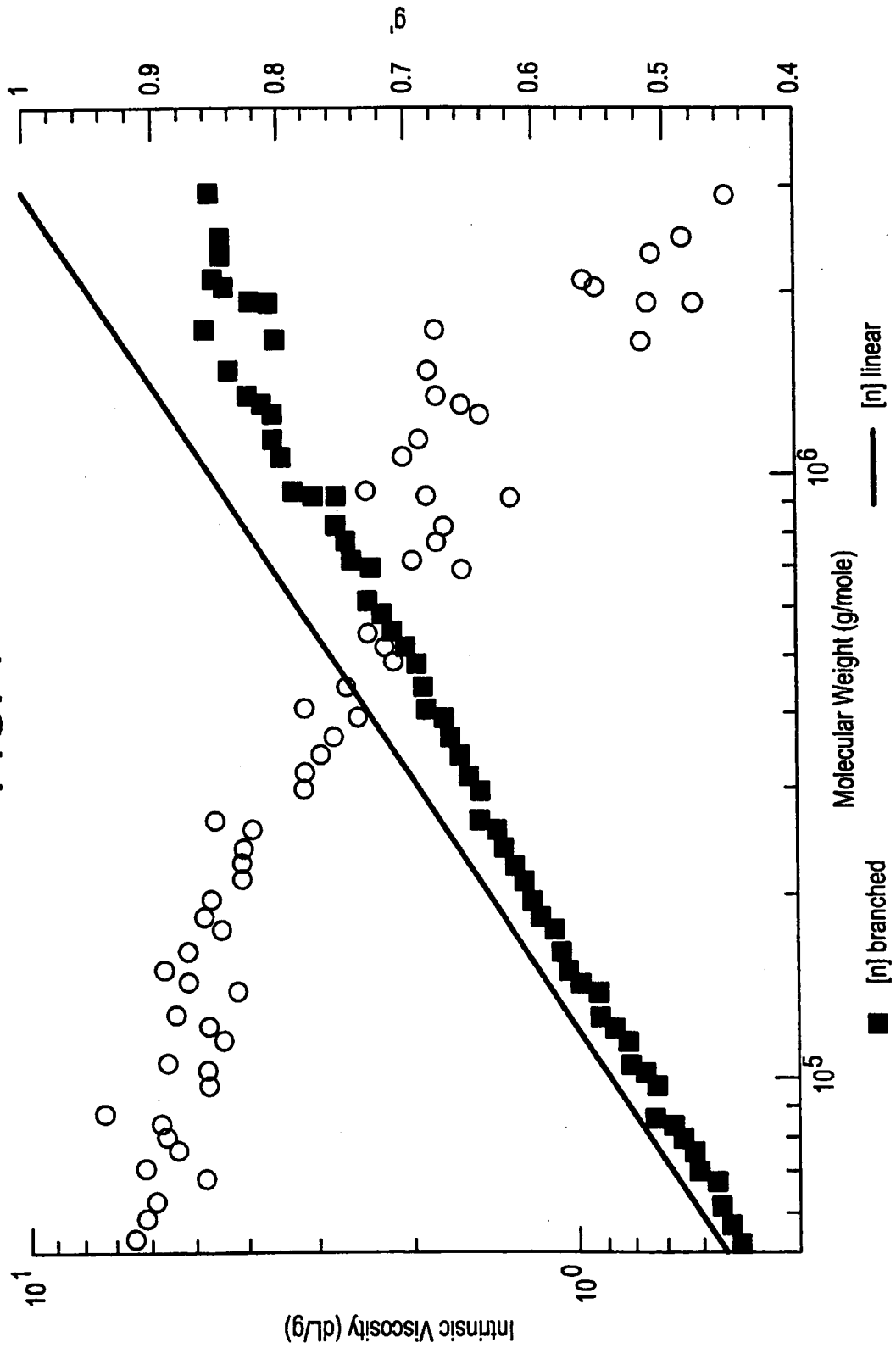

FIG. 2

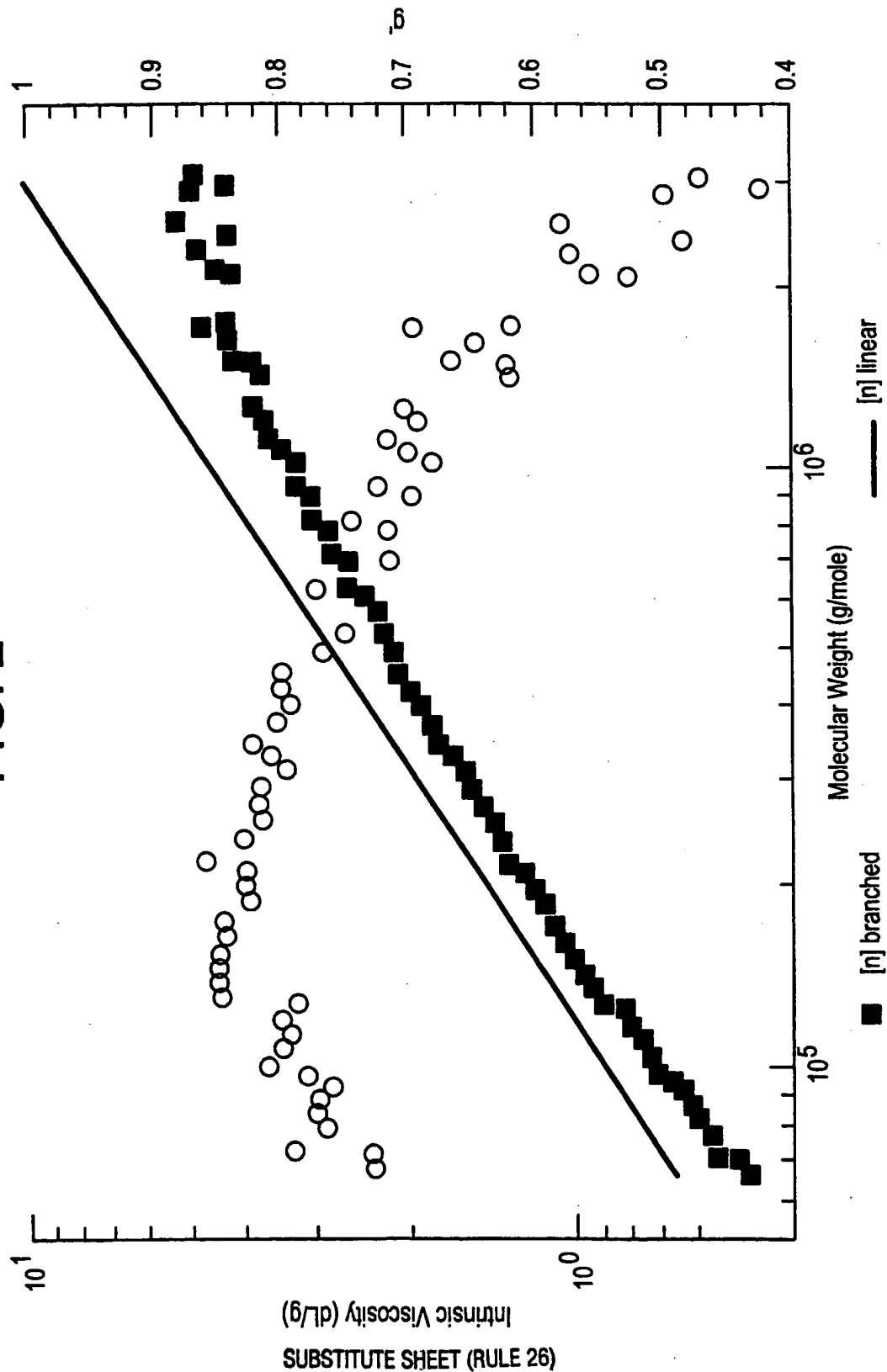

FIG. 3

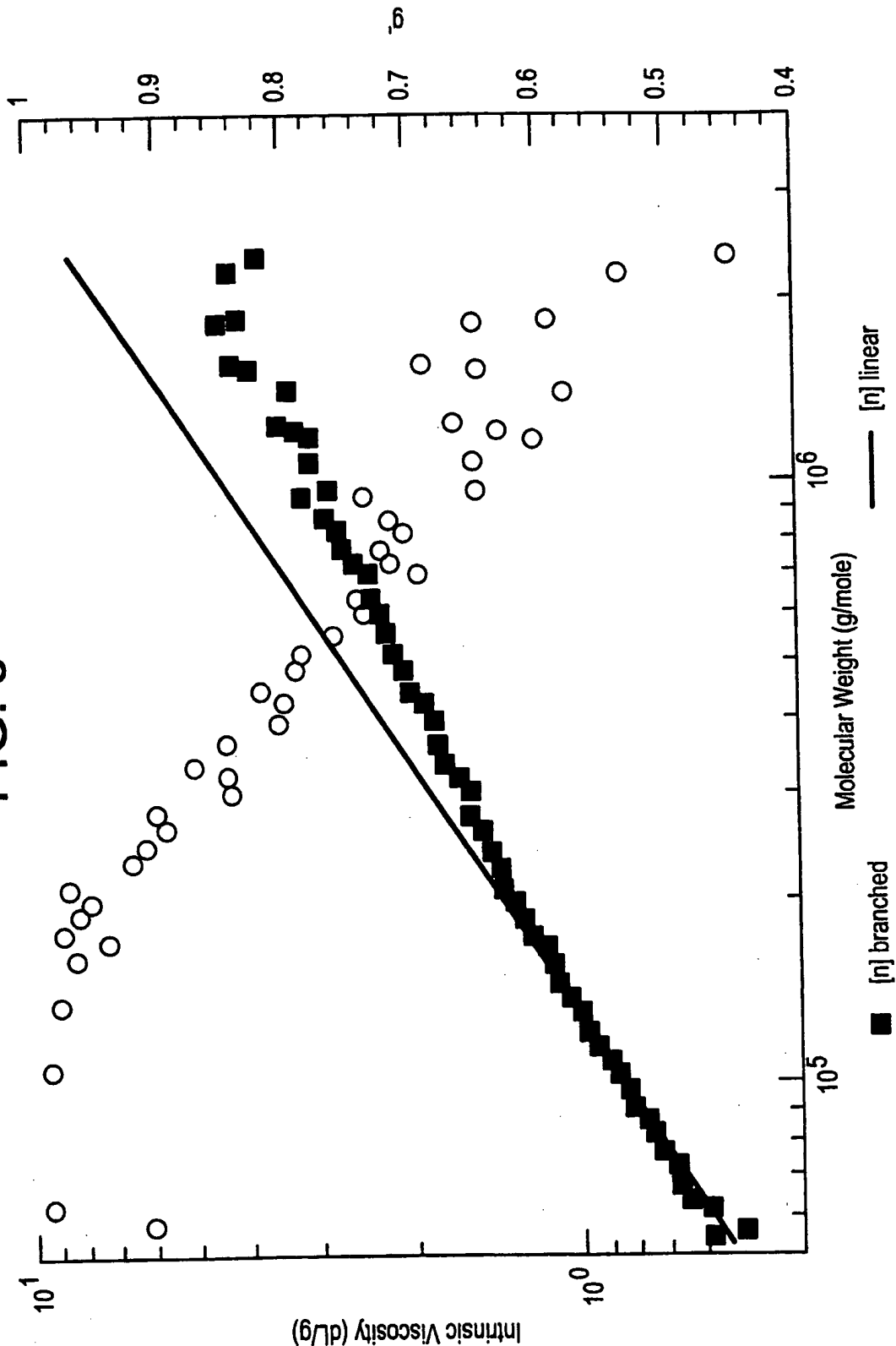
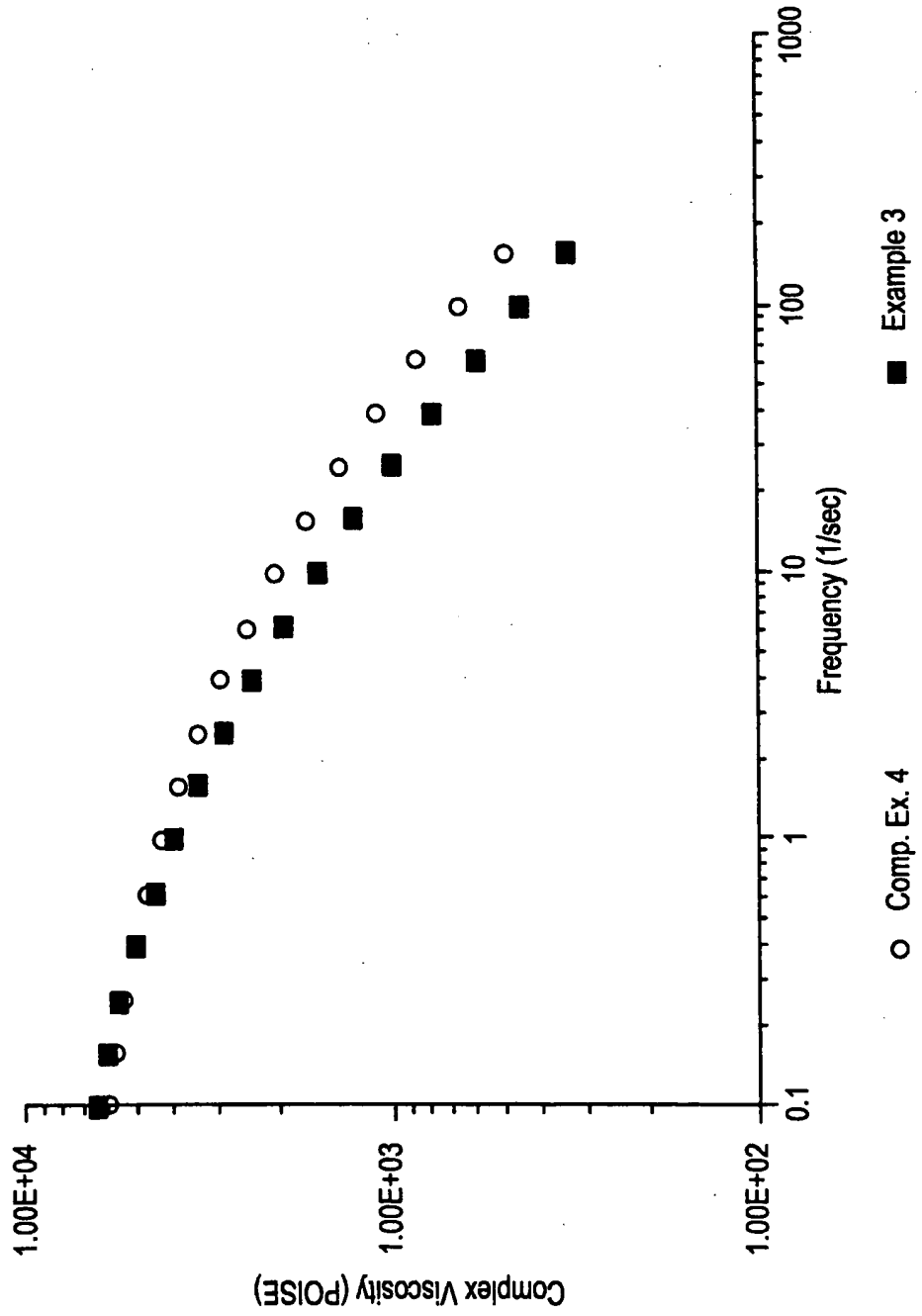

FIG. 4



INTERNATIONAL SEARCH REPORT

Int. l. Application No
PCT/US 98/24077

A. CLASSIFICATION OF SUBJECT MATTER IPC 6 C08F10/06 C08F210/06 C08F4/64 C08F2/00		
According to International Patent Classification (IPC) or to both national classification and IPC		
B. FIELDS SEARCHED Minimum documentation searched (classification system followed by classification symbols) IPC 6 C08F		
Documentation searched other than minimum documentation to the extent that such documents are included in the fields searched		
Electronic data base consulted during the international search (name of data base and, where practical, search terms used)		
C. DOCUMENTS CONSIDERED TO BE RELEVANT		
Category *	Citation of document, with indication, where appropriate, of the relevant passages	Relevant to claim No.
X	WO 94 07930 A (EXXON CHEMICAL PATENTS INC) 14 April 1994 see column 3, line 34 - column 4, line 14 ---	1-6
X	US 4 916 198 A (SCHEVE B JOSEPH ET AL) 10 April 1990 see column 3, line 36 - column 4, line 12 ---	1-6
X	US 5 554 668 A (SCHEVE B JOSEPH ET AL) 10 September 1996 see column 3, line 36 - column 4, line 12 ---	1-6
X	US 5 591 785 A (SCHEVE B JOSEPH ET AL) 7 January 1997 see column 20, line 1; examples 1-6 --- -/--	7-28
<input checked="" type="checkbox"/> Further documents are listed in the continuation of box C.		
<input checked="" type="checkbox"/> Patent family members are listed in annex.		
* Special categories of cited documents :		
"A" document defining the general state of the art which is not considered to be of particular relevance "E" earlier document but published on or after the international filing date "L" document which may throw doubts on priority claim(s) or which is cited to establish the publication date of another citation or other special reason (as specified) "O" document referring to an oral disclosure, use, exhibition or other means "P" document published prior to the international filing date but later than the priority date claimed		
"T" later document published after the international filing date or priority date and not in conflict with the application but cited to understand the principle or theory underlying the invention "X" document of particular relevance; the claimed invention cannot be considered novel or cannot be considered to involve an inventive step when the document is taken alone "Y" document of particular relevance; the claimed invention cannot be considered to involve an inventive step when the document is combined with one or more other such documents, such combination being obvious to a person skilled in the art. "A" document member of the same patent family		
Date of the actual completion of the international search <p style="text-align: center;">29 March 1999</p>	Date of mailing of the international search report <p style="text-align: center;">26/04/1999</p>	
Name and mailing address of the ISA European Patent Office, P.B. 5818 Patentlaan 2 NL - 2280 HV Rijswijk Tel. (+31-70) 340-2040, Tx. 31 651 epo nl, Fax: (+31-70) 340-3016	Authorized officer <p style="text-align: center;">Van Golde, L</p>	

INTERNATIONAL SEARCH REPORT

International Application No

PCT/US 98/24077

C.(Continuation) DOCUMENTS CONSIDERED TO BE RELEVANT

Category *	Citation of document, with indication, where appropriate, of the relevant passages	Relevant to claim No.
A	US 5 516 848 A (CANICH JO ANN M ET AL) 14 May 1996 see the whole document -----	7,18

INTERNATIONAL SEARCH REPORT

Information on patent family members

International Application No

PCT/US 98/24077

Patent document cited in search report	A	Publication date	Patent family member(s)	Publication date
WO 9407930	A	14-04-1994	AU 4928993	26-04-1994
			CA 2145635	14-04-1994
			EP 0662980	19-07-1995
			JP 8502303	12-03-1996
US 4916198	A	10-04-1990	US 5731362	24-03-1998
			US 5554668	10-09-1996
			US 5591785	07-01-1997
			AT 88196	15-04-1993
			AU 616106	17-10-1991
			AU 5215890	19-07-1990
			AU 597241	31-05-1990
			AU 5284386	07-08-1986
			AU 7942891	12-09-1991
			BR 8600413	14-10-1986
			CA 1280543	19-02-1991
			CN 1030199	01-11-1995
			CN 1041769	02-05-1990
			DE 3688258	19-05-1993
			EP 0190889	13-08-1986
			IN 166935	11-08-1990
			IN 170549	11-04-1992
			JP 7045551	17-05-1995
			JP 62121704	03-06-1987
			PT 81945	30-12-1987
RU 2031906	27-03-1995			
US 5554668	A	10-09-1996	US 4916198	10-04-1990
			US 5591785	07-01-1997
			US 5731362	24-03-1998
			AT 88196	15-04-1993
			CA 1280543	19-02-1991
			CN 1041769	02-05-1990
			DE 3688258	19-05-1993
			EP 0190889	13-08-1986
			IN 170549	11-04-1992
			AU 616106	17-10-1991
			AU 5215890	19-07-1990
			AU 597241	31-05-1990
			AU 5284386	07-08-1986
			AU 7942891	12-09-1991
			BR 8600413	14-10-1986
			CN 1030199	01-11-1995
			IN 166935	11-08-1990
			JP 7045551	17-05-1995
			JP 62121704	03-06-1987
			PT 81945	30-12-1987
RU 2031906	27-03-1990			
US 5591785	A	07-01-1997	US 4916198	10-04-1990
			US 5554668	10-09-1996
			US 5731362	24-03-1998
			AT 88196	15-04-1993
			CA 1280543	19-02-1991
			CN 1041769	02-05-1990
			DE 3688258	19-05-1993
			EP 0190889	13-08-1986
			IN 170549	11-04-1992

INTERNATIONAL SEARCH REPORT

Information on patent family members

Int'l Application No PCT/US 98/24077
--

Patent document cited in search report	Publication date	Patent family member(s)	Publication date
US 5591785 A		AU 616106 B	17-10-1991
		AU 5215890 A	19-07-1990
		AU 597241 B	31-05-1990
		AU 5284386 A	07-08-1986
		AU 7942891 A	12-09-1991
		BR 8600413 A	14-10-1986
		CN 1030199 B	01-11-1995
		IN 166935 A	11-08-1990
		JP 7045551 B	17-05-1995
		JP 62121704 A	03-06-1987
		PT 81945 B	30-12-1987
		RU 2031906 C	27-03-1990
US 5516848 A	14-05-1996	CA 2209773 A	08-08-1996
		EP 0807143 A	19-11-1997
		JP 11500474 T	12-01-1999
		WO 9623838 A	08-08-1996